

VARIABLE MASS SYSTEMS DYNAMICS IN ENGINEERING MECHANICS EDUCATION

Celso Pupo Pesce, cepcesce@usp.br

Leonardo Casetta, lecasetta@ig.com.br

LIFE&MO - Fluid-Structure Interaction and Offshore Mechanics Laboratory
Mechanical Engineering Department
Escola Politécnica, University of São Paulo

Abstract. *Variable mass systems have been the focus of a large number of problems in classical mechanics. However, despite the classic nature and importance of variable mass systems dynamics, many misinterpretations were done on the correct application of Newton's second law, even in a not so distant past. Such misinterpretations sometimes give rise to apparent paradoxes in Classical Mechanics. For instance, motivated by the rocket problem, a long debate on the correct application of Newton's law took place during the 1960's, among American scholars and educators. Even subtler may be the proper application and interpretation of the Lagrangian formalism to systems presenting mass dependence on time, position (and velocity). The subject has not always been deeply discussed in Engineering Mechanics Education and, even worse, not always properly included in many modern Engineering Courses curricula, at both undergraduate and graduate levels. The purpose of the present paper is, therefore, to re-address such an important matter, aiming at contributing to Engineering Mechanics Education, by discussing under a historical perspective some theoretical aspects involved in variable mass systems dynamics which are usually hidden behind many derivations.*

Keywords: *variable mass systems, Engineering Mechanics, Education, Newton's Law, Meshchersky Equation, Lagrange Equation.*

1. INTRODUCTION

Variable mass systems have been the focus of a large number of problems in classical mechanics. According to Šíma and Podolský (2005), the Czech scientist and inventor von Buquoy "was the first to investigate systems with a varying mass". "In 1812 he explicitly formulated the correct dynamical equation of motion for the case when the mass of a moving object is changing"; see von Buquoy (1812), page 66, *apud* Šíma and Podolský (2005). His work was then presented in 1815, von Buquoy (1815), at the Paris Academy of Sciences. Also according to Šíma and Podolský, "apart from a single short article by Poisson (1819), his ideas did not attract attention, and they gradually become forgotten. Buquoys's general equation of motion and other explicit examples were later formulated independently by various authors"; to be mentioned, Tait and Steele (1856) and Meshchersky (1897), *apud* Šíma and Podolský (2005).

In particular, Meshchersky (1897) Master Thesis, and his subsequent work written in 1904, have been ever since recognized - in the Russian technical literature - as the limestone in the study of variable mass systems in the context of Classical Mechanics; see, e.g., Targ (1976), page 394 or Starjinski (1980), page 498. The Russian technical literature is indeed rich in examples of variable mass systems, since this early work which interpreted Newton's law for the general case of continuously ejected (accreted) mass with non-null velocity. In fact, this interpretation is commonly cited in Russian and Eastern European texts as Meshchersky's Equation, and the reaction (or thrust) force, that is explicitly shown to be proportional to the relative velocity between the particle and the ejected mass, is known as Meshchersky's force.

Other important and early pioneering work should also be cited. In 1857 Cayley (1857) discussed the problem of a chain being coiled up at a table. Levi-Civita (1928, 1930) treated the motion of a variable mass point body in the two-body problem, introducing an extended form of Newton's law. Such a form, however, is only valid if mass is ejected or accreted with null velocity with respect to an inertial frame, as it will be discussed in the present paper.

During the 1950's and 60's a renewed interest in this subject came into play with the 'rocket problem' and the emerging Aerospace Engineering. Apart the 'rocket problem', another special class, related to tethered satellite systems, might also be cited; see, e.g., Crellin *et al.* (1995, 1997). From another practical side, the textile industry has been a source of variable mass systems problems in Engineering Mechanics; see the works of Cveticanin (1984, 1989, 1992, 1993a, 1993b). All those applied research activities gave rise to the need of new theoretical investigations, as those carried out in the 1980's and 90's by Ge, (1982, 1984) and by Cveticanin (1993b). Open systems approaches have also been a very interesting field to which proper theoretical formulations for variable system dynamics gained renewed interest, as testimonies the work of McIver (1973) and, more recently, those by Mušicki (1999, 2000) and the review by Irschik and Holl (2004).

However, despite the classic nature and importance of variable mass systems dynamics, many misinterpretations were done on the correct application of Newton's second law, even in a not so distant past. For instance, motivated by the rocket problem - and by some controversy aroused from distinct interpretations - a long debate on the correct application of Newton's law took place during the 1950's and 60's, amongst American scholars and educators: "...this

basic law of mechanics is currently being *seriously*¹ misinterpreted. This misinterpretation appears under conditions where the mass of a body is a function of time”, Meriam (1960); “There exists considerable confusion and disagreement among professional physicists concerning the correct classical equations of motion for systems of changing mass...”, Tiersten (1969). And, even recently, “despite the fact that variable mass dynamics has been an active research field for many years, we still find in the literature wrong applications of Newton’s second law in this context...”, Plastino and Muzzio (1992).

Much subtler may be the proper application and interpretation of the Lagrangian formalism to systems presenting explicitly mass dependence on position (and on velocity²); see, for example, the works of Cveticanin (1993b), Irschik and Holl (2002), Pesce (2003) and Mušicki (2005).

Those misinterpretations sometimes gave rise to apparent paradoxes in Classical Mechanics, most of them involving energy conservation principles. Examples on that are the case of some treatments given to the well-known chain problem coiled up at a table, where a continuous impact is involved, or the analogous case of the impact of a rigid body against the free surface of a liquid; see Pesce (2003, 2005), Casetta and Pesce (2006, 2007).

All those aspects have not always been deeply discussed in Engineering Mechanics Education and, worse, not always included in many modern Engineering Courses *curricula*, at both undergraduate and graduate levels. The purpose of the present paper is, therefore, to re-address such an important theme, aiming at contributing to Engineering Mechanics Education by re-addressing theoretical aspects often involved in variable mass systems dynamics, which are usually hidden behind many derivations.

In Sec. 2, the proper Meshchersky form of Newton’s law for continuously varying mass particles is re-addressed. A short review on the evolution of some historical notes which may have contributed to the formalization of such law of motion is done. Simple and usual didactic examples enlightening the usage of Newton’s law in problems involving variable mass particles (or subsystems) are discussed. In Sec. 3, it is shown that despite the well-known generality of Lagrange’s Equation, modified forms for the generalized force may be required in the analysis of cases involving variable mass problems. A simple example is shown.

2. NEWTON’S SECOND LAW OF MOTION AND VARIABLE MASS SYSTEMS

According to Arons and Bork (1964), the term ‘law of motion’ was introduced in the 17th century by Descartes. After stating the law of inertia in an essentially modern form, Descartes stated a law of conservation of momentum with respect to its magnitude only, and not to direction, and continued with a list of ‘laws of impact’ which involved the impact between solid bodies. At the beginning of his famous work, *Philosophiae Naturalis Principia Mathematica*, Newton asserted the so-called ‘laws of motion’, which is more than a result of an appreciation of previous works. To Arons and Bork, “rather than dealing with relations between initial and final conditions in an interacting system, as done by Descartes, Newton dealt directly with the effect of the forces acting on individual bodies...” However, when Newton discussed the motion of bodies, the trajectories were conic sections and not straight lines or other paths, and the forces considered by him were central forces. Apparently, he showed no interest in the mechanical problems usually found in today textbooks, particularly the variable mass ones. Paradoxically, according to Dugas (1951), “Newton introduced the notion of mass into Mechanics³”, even though “this notion had appeared in Huyghen’s work, but only in an impermanent form”.

To analyze the motion of the planets, Newton needed to focus his attention on the history of the motion of a single body, and not on the whole interacting system. In this sense, Arons and Bork (1964) pointed out: “it seems quite possible that, motivated by this need, he discovered in the ‘third law of motion’⁴ a way of separating or isolating an individual body from the rest of the system with which it is interacting”. “Given equal and opposite action of bodies on each other (third law), consistency with the known laws of impact required that these actions imparted equal and opposite changes of momentum. Thus, Newton might naturally have been led to his second law⁵. In recent years, many authors pointed out that in using the term ‘motive force’ Newton was referring to what we call ‘impulse’”.

However, Newton’s law is sometimes written, even for a single particle, not as a statement which relates impulse and momentum, but as (see, e.g., Goldstein (1981), chapter1),

$$\mathbf{F} = \frac{d}{dt}(m\mathbf{v}), \quad (1)$$

¹ Authors’ enhancement.

² Not in a relativistic sense, though.

³ “Definition I – The Quantity of Matter is the measure of the same, arising from its density and bulk conjunctly”; Dugas (1951), page 201.

⁴ “Law III - To every action there is always opposed an equal reaction – or the mutual actions of the two bodies upon each other are always equal, and directed to contrary parts”; Dugas (1951), page 206.

⁵ “Law II - The alteration of [the quantity] of motion is ever proportional to the motive force impressed; and is made in the direction of the right line in which that force is impressed”; Dugas (1951), page 206.

being \mathbf{F} the resultant of all external impressed forces, m the mass of the body and \mathbf{v} its velocity vector. The key point is that this interpretation of Newton's second law is of restricted validity in Mechanics⁶. Considering it applied to a single particle, such a form may be encountered in Levi-Civita's work (1928), and is only valid if mass is constant or if it is accreted (ejected) at null velocity with respect to the inertial frame of reference. In the case of variable mass systems (the concept of an open system should be here evoked), Eq. (1) is not generally valid. On the other hand, in this form, Eq. (1) violates the relativity principle under Galilean transformations (see Appendix) – an obvious exception if mass is invariant – and, therefore, cannot be considered as Newton's second law, but as a particular case of it. As already mentioned, this issue was early addressed by von Buquoy (1812), Tait (1856) and Meshchersky (1897).

Nonetheless, from a recent perspective, according to Plastino and Muzzio (1992), this particular form of Newton's law, Eq. (1), "was popular in textbooks, decades ago, because it was then in the vogue to consider that, according to special relativity, mass depended on velocity".

The derivation of the proper Newton's law for variable mass system might not be considered straightforward, since the original one was formulated for a definite set of particles or rigid bodies. According to Eke and Mao (2002), an interesting manner to overcome this difficulty is to model variable mass systems in a way that allows them to be viewed as constant mass systems, and thus make them amenable to treatment by existing principles of dynamics. Such models will not be explored here, but a brief discussion on some of them can be found in Irschik and Holl (2002) and Ambrosi and Mollica (2002). A didactical manner to derive the proper Newton's law of motion for simple variable mass systems is the one due to Meriam (1960) and/or to Leitmann (1957). Their technique consists in considering a set of constant-mass particles. Newton's law is then applied to the whole system, but the particles are labeled in order to be possible distinguishing those particles which, at a certain instant of time, belong to a considered partial system and those which do not. Simple algebraic manipulations and the assumption of validity of the principle of conservation of mass, applied to the whole system, lead to Newton's law in its most general form, i.e.

$$\mathbf{F} + \frac{dm}{dt} \mathbf{u} = \frac{d}{dt}(m\mathbf{v}), \quad (2)$$

where \mathbf{v} is the velocity of the particle under study, that is gaining (losing) mass at a time rate dm/dt and \mathbf{u} is the velocity vector of the accreted ($dm/dt > 0$) or ejected ($dm/dt < 0$) mass, to/from the system, both velocities obviously measured in the same inertial frame of reference. Note that Eq. (1) is promptly recovered from Eq. (2) in the particular (Levi-Civita's) case where mass is accreted (ejected) with null velocity. Equation (2) is also usually written in terms of the relative velocity between the particle and the accreted (ejected) mass,

$$m \frac{d\mathbf{v}}{dt} = \mathbf{F} + \Phi = \mathbf{F} + \frac{dm}{dt} \mathbf{u}_{rel}, \quad \mathbf{u}_{rel} = \mathbf{u} - \mathbf{v}. \quad (3)$$

This form of Newton's Law is due to Meshchersky (see Appendix) who, in the end of the 19th and beginning of the 20th centuries, pioneered studying the dynamics of a variable mass point; Meshchersky (1897, 1904). Equation (3) is known as Meshchersky's Equation in the Russian technical literature. The reaction force $\Phi = \dot{m} \mathbf{u}_{rel}$ is known as Meshchersky's force. In 1903, according to Starjinski (1980), page 498, the Russian scientist Tsiolkovski - who had invented a kind of rocket-aircraft twenty years before that - applied Meshchersky's Equation to solve the rocket problem in two versions: (i) *gravity-free* and (ii) *non-gravity-free*. Those two problems are sometimes referred to as the first and the second problems of Tsiolkovski.

Most text books, either at undergraduate or graduate level, mention variable mass systems. Nonetheless, to these authors knowledge, there are not so many of them presenting comprehensive and properly didactic treatments of Newton's second law. Examples, in this sense, are Inglis (1951), Targ (1976), Starjinski (1986), José and Saletan (1998).

In many other undergraduate and graduate texts, either the problem is simply not addressed (some times just mentioned) or is treated only when dealing with the 'rocket problem'. Meriam and Kraige (1987) or Borelli and Schmidt (1954) are examples of this last approach.

Worse, there are even some classics that give wrong treatments to the problem, stating Eq. (1) as generally valid for a single varying mass particle, with no further consideration; see, e.g., Goldstein (1950, 1981), chapter 1, Singe and Griffith (1959), chapter 12. The reasons for this are not clear to the present authors, but certainly influenced the surprising debate occurred among American educators in the 1950's and 60's.

It is also interesting to mention that Eq. (2) can also be conceived by recovering the following axiom of mechanics: *any change whatsoever in the quantity of any entity within a closed surface can be affected in one or other of two distinct ways: it may be affected by the production or destruction of the entity within the domain, or by the passage of the entity across the domain due to its transportation by particles*; see Irschik and Holl (2004) for a detailed discussion on the application of general laws of balance and the generalized transport theorem. According to Thompson (1988), the

⁶ Eq. (1), in the form, $\mathbf{F} = \frac{d\mathbf{p}}{dt}$, is always valid if one thinks of an invariant mass system being \mathbf{p} the total momentum.

time rate of change momentum of an open system (the first parcel of the right-hand side of Eq. (2)) can be created or destroyed by the action of the impressed forces (the left-hand side of Eq. (2)) or carried into the domain or out of it by means of a flux of mass with non-null velocity (the second term of the right-hand side of Eq. (2)).

2.1. Simple Didactic Examples

Consider, *first*, an open system consisting of an open-topped freight car which can accumulate water (or seeds) which is (are) being dropped from an external pipe. Besides vertical reactions and weight, no other external forces act on the system, particularly not in the horizontal direction. For the sake of simplicity a ‘fixed frame’ of reference is adopted.

In order to analyze the motion of the system formed by the car plus the amount of dropped water (or seeds), Eq. (2) (or 3) must be used. At first, let us assume that the pipe is fixed at a position, and the car is filled with some finite amount of water when it passes through this position. Since the pipe is fixed, the horizontal velocity of the water flow is zero, i.e. mass is accreted with zero horizontal velocity, $u_x = 0$. If m is the mass of the system and v_x its horizontal velocity, Eq. (2) then leads to

$$\frac{d}{dt}(mv_x) = 0 \quad (4)$$

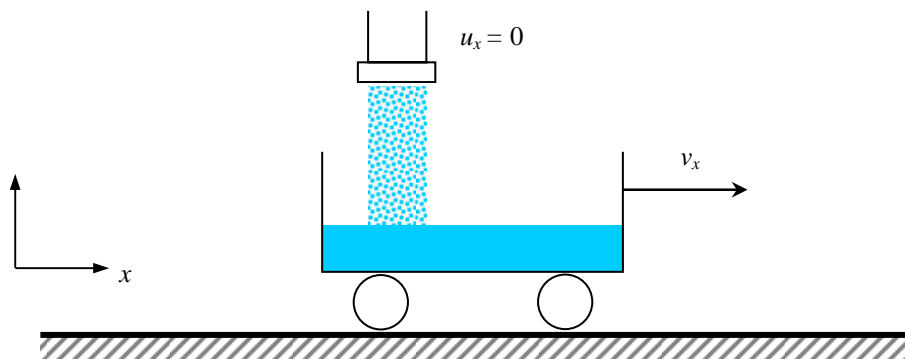

Figure 1. Sketch of the horizontal motion of an open-topped freight car that is filled with water, from a fixed pipe.

By integrating Eq. (4) between some instant of time before the car is under the pipe and some after that, we have

$$v_{x,after} = \frac{m_{before}}{m_{after}} v_{x,before} \quad (5)$$

As $m_{after} > m_{before}$ after passing through the pipe, the velocity of the system is clearly reduced.

Let us now assume that the pipe follows the car and thus water is always being dropped into it (see Fig. 2). In this case, mass is accreted with the same horizontal velocity of the car, i.e. $u_x = v_x$.

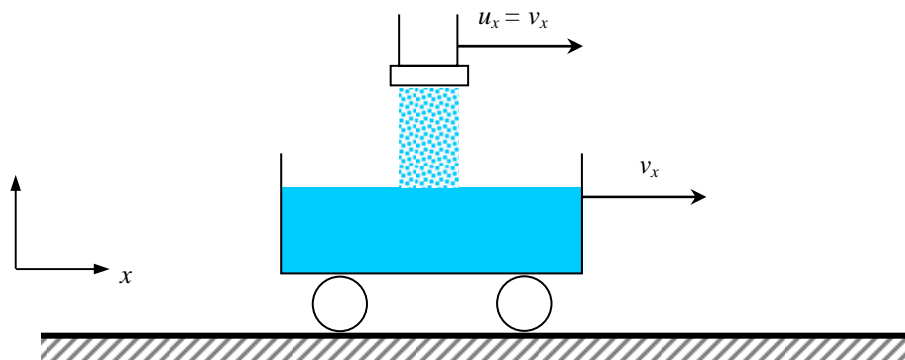

Figure 2. Sketch of the horizontal motion of an open-topped freight car that is filled of water, from a pipe with the same horizontal velocity as the car.

In this case, Eq. (2) becomes

$$\frac{d}{dt}(mv_x) - \frac{dm}{dt}v_x = 0 \Rightarrow m \frac{dv_x}{dt} = 0. \quad (6)$$

One can then conclude from Eq. (6) that

$$v_{x,after} = v_{x,before}. \quad (7)$$

At a first sight, this result could be sought against a naïve intuition, since, although the mass of the system increases with time, its velocity remains the same.

Take now the *classical rocket problem*. The whole system has invariant mass, m . Eq. (1) could then be applied to the whole (constant mass) system, which could then be divided into two exchanging mass subsystems; i.e., the rocket plus the non-burned fuel, with mass m_1 , and the burned fuel (the expelled gases), with mass m_2 , with $\dot{m}_1 = -\dot{m}_2 < 0$ (see Fig. 3). However, care should be taken in interpreting the fluxes of exchanging mass between the two subsystems and their relations with respect to the respective positions of the two centers of mass, together with their respective velocities and accelerations⁷. See the works by Thorpe (1962) and by Tiersten (1969), for an enlightening discussion on this subject.

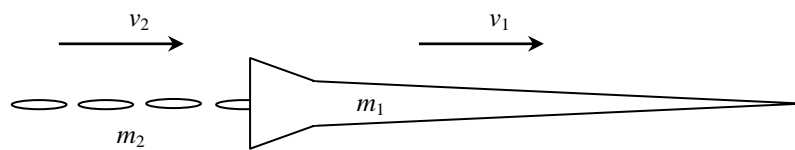

Figure 3. Illustration of the rocket problem. Partition of the whole system into two subsystems.

On the other hand, from the simpler (and approximate) point of view of particle dynamics, Eq. (2) might be applied to the subsystem of mass m_1 (rocket + non-burned fuel), now taken as a single particle, and to *another* second subsystem, composed, at each instant of time, by an expelled (carrying-mass) particle, of mass μ , that is incorporated to the gas tail. The resultant of external forces acting on those two subsystems are the sum $F = F_1 + f$, where f is the total external force acting just on the expelled particle. Taking u as the velocity of the expelled particle, it follows, from Eq. (2), that,

$$\begin{aligned} F_1 + \frac{dm_1}{dt}u &= \frac{d}{dt}(m_1v_1), \\ f + \frac{d\mu}{dt}u &= \frac{d}{dt}(\mu u) \end{aligned} \quad (8)$$

or else, recalling that $\dot{m}_1 = -\dot{\mu} < 0$, Eqs. (8) may be written in Meshchersky's form, as

$$\begin{aligned} m_1\dot{v}_1 &= F_1 - \dot{m}_1(v_1 - u) \\ \mu\dot{u} &= f \end{aligned} \quad (9)$$

De Souza and Rodrigues (2004) argue that such a kind of splitting is didactically fruitful since Eqs. (8) present a common generic structure. Note that summing up Eqs. (8a) and (8b) does recover Eq. (1) for this two-particle system. Both fluxes of mass cancel each other; i.e. the second terms in the left-hand sides play the role of an action-reaction pair, what they indeed are.

3. THE APPLICATION OF LAGRANGE EQUATION TO VARIABLE MASS SYSTEMS

Within Analytical Mechanics, under the Lagrangian formalism, some special care may be also needed, when dealing with variable mass systems. At first, recall that the original form of Lagrange Equation, namely,

$$Q_j = \frac{d}{dt} \left(\frac{\partial T}{\partial \dot{q}_j} \right) - \frac{\partial T}{\partial q_j}, \quad (10)$$

with,

$$Q_j = \sum_i \mathbf{F}_i \cdot \frac{\partial \mathbf{P}_i}{\partial \dot{q}_j}, \quad (11)$$

⁷ It should be noted that, actually, the position of the center of mass of the rocket + unburned fuel varies with respect to a reference system fixed at the rocket, say the nozzle. So does the position of the center of mass of expelled gases, with respect to the nozzle.

where T is the kinetic energy of the system, Q_j is the j -th generalized force and q_j the corresponding generalized coordinate, was also derived for a definite i -set of constant-mass particles; see, e.g. Eke and Mao (2002). Curiously, *this same form may be also applied to systems with varying mass*. However, *the generalized forces must be redefined accordingly*. The explanation for this kind of invariance is quite subtle and may be disclosed in the derivation of Lagrange Equation as obtained through the application of the Principle of Virtual Work to D'Alembert's Principle; see Pesce (2003), for a detailed discussion on this matter. Usually, though, this invariance property is not comprehensively covered, in most text books, even in classic ones; see, e.g., Lanczos (1949), Whittaker (1965), Pars (1965), Landau and Lifschitz (1966).

In the simpler, usual and first varying mass case, in which the variation of mass is given as an explicit function of time, in the form $m = m(t)$, it is sufficient to redefine the generalized force as; see, e.g., Cveticanin (1993b) or Pesce (2003),

$$Q_j = \sum_i (\mathbf{F}_i + \dot{m}_i \mathbf{u}_i) \cdot \frac{\partial \mathbf{P}_i}{\partial \dot{q}_j}, \quad (12)$$

where \mathbf{u}_i is the velocity of the accreted (ejected) mass to (from) the particle i . However, in a second and more general case, in which masses are considered as functions of position and time, $m_i = m_i(q_j; t)$, the generalized forces read; see Pesce (2003)⁸

$$Q_j = \sum_i (\mathbf{F}_i + \dot{m}_i \mathbf{u}_i) \cdot \frac{\partial \mathbf{P}_i}{\partial \dot{q}_j} - \sum_i \frac{1}{2} \frac{\partial m_i}{\partial q_j} (\mathbf{v}_i)^2. \quad (13)$$

Finally, in the third and most general case that might be conceived in the context of Mechanics, when masses are considered as functions of position, time and (possibly) velocities, $m_i = m_i(q_j, \dot{q}_j; t)$, the generalized forces read; see Pesce (2003),

$$Q_j = \sum_i (\mathbf{F}_i + \dot{m}_i \mathbf{u}_i) \cdot \frac{\partial \mathbf{P}_i}{\partial \dot{q}_j} + \sum_i \left\{ \frac{1}{2} \frac{d}{dt} \left(\frac{\partial m_i}{\partial \dot{q}_j} (\mathbf{v}_i)^2 \right) - \frac{1}{2} \frac{\partial m_i}{\partial q_j} (\mathbf{v}_i)^2 \right\}. \quad (14)$$

Therefore, analogously to Newtonian Mechanics, unless further considerations regarding the definition of generalized forces are made, the classical form of Lagrange equation is only applicable to the very particular case in which mass is accreted (ejected) with null (absolute) velocity and, moreover, given solely as function of time (explicit dependences on position or velocity otherwise precluded).

3.1 A Simple Didactic Example

The same examples presented in Sec. 2 can be alternatively solved through the application of Eqs. (10)-(12). Let us, instead, consider another didactic problem which may require the application of Eq. (13). Suppose a heavy cable being deployed from a reel by the action of gravity as in Fig. 4. This same example and two other problems in Offshore Engineering are treated in Pesce et al. (2006).

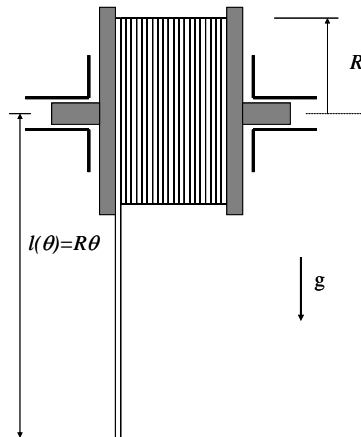

Figure 4. Sketch of a heavy cable being deployed from a reel under the action of gravity.

⁸ See also Cveticanin (1993b) for an equivalent form of this extended Lagrange Equation, where Meshchersky's force appears explicitly.

The angle θ , the generalized coordinate, is such that the cable suspended length can be given by $L_s = R\theta$. If L is the entire length of the cable and, μ its density per unit length, $m_s = \mu R\theta$ and $m_w = \mu(L - R\theta)$ are, respectively, the mass of the suspended and wound parts. Note that mass enters into the suspended and leaves the wound part with velocity $u = R\dot{\theta}$. Suppose now that, for some practical reason, the analyst is interested in the subsystem composed by the reel and the wound portion, i.e., a variable mass system.

The traction T which acts on the system can be obtained by the application of Eq. (2) in the suspended part

$$T - m_s g = \frac{d}{dt}(m_s R\dot{\theta}) - \frac{dm_s}{dt} R\dot{\theta}, \quad (15)$$

which can be integrated to give

$$T = m_s (g - R\ddot{\theta}). \quad (16)$$

Letting $I = I_0 + m_w R^2 = I_0 + \mu R^2 (L - R\theta)$ be the moment of inertia of the reel, I_0 , plus the one of the wound part, $m_w R^2 = \mu R^2 (L - R\theta)$, the kinetic energy of the considered subsystem is then given by $T = \frac{1}{2} I \dot{\theta}^2 = \frac{1}{2} [I_0 + \mu R^2 (L - R\theta)] \dot{\theta}^2$. If, erroneously, Lagrange equation in the form of Eq. (10)-(11) is applied, with $Q = (T + \dot{m}_w R\dot{\theta})R$, $q = \theta$ and $T = \frac{1}{2} I \dot{\theta}^2 = \frac{1}{2} [I_0 + \mu R^2 (L - R\theta)] \dot{\theta}^2$, the obviously incorrect equation of motion is obtained:

$$(I_0 + \mu L R^2) \ddot{\theta} + \frac{1}{2} \mu R^3 \dot{\theta}^2 - \mu g R^2 \theta = 0. \quad (17)$$

Note that, as written above, the mass of the reel plus the wound portion is explicitly dependent on the generalized coordinate, and so Eq. (13) must be used to give the proper equation of motion, i.e.

$$(I_0 + \mu L R^2) \ddot{\theta} - \mu g R^2 \theta = 0. \quad (18)$$

Eq. (18) is indeed the correct equation of motion and might have been obtained by directly applying the classical form of the Lagrange's Equation, Eq. (10-11), to the system, then to be considered as a whole, hence of invariant mass.

4. CONCLUSIONS

Problems of variable mass systems in Engineering Mechanics are rather classical and a very well explored subject in the technical literature, since von Buquoy's work, in 1812-1815 and Metchersly's, in 1897. Nevertheless, its subtlety sometimes reserve trappings to students and even to scholars. As a matter of fact, much work is still being carried out on the subject, as testimonies the recent review by Irschik and Holl (2004). Sometimes, motivated by nonlinear dynamics applications, aroused from engineering problems, other times by theoretical issues, see, e.g. Mušicki (2005), variable mass system dynamics is still a state-of-the-art matter. Nevertheless, from time to time, misinterpretations are found on the correct application of Newton's second law or concerning the Lagrangian Equation to this kind of systems. The present paper aimed at contributing to Engineering Mechanics Education by re-addressing former discussions from a historical perspective, otherwise hoping to stimulate students and scholars to reflect on some theoretical aspects that are usually hidden behind many derivations.

5. ACKNOWLEDGEMENTS

The authors acknowledge FAPESP, the São Paulo State Research Foundation, PhD scholarship, n° 04/04611-5 and CNPq, The Brazilian National Research Council, Research Grant n° 301928/2005-3.

6. REFERENCES

- Ambrosi, D., Mollica, F., 2002, "On the Mechanics of a Growing Tumor", *International Journal of Engineering Science*, Vol.40, pp. 1297-1316..
- Arons, A.B., Bork, A.M., 1964, "Newton's Law of Motion and the 17th Century Laws of Impact", *American Journal of Physics*, Vol.32, No. 4, pp. 313-317.
- Boresi, A.P., Schmidt, R.J., 1954, *Dinâmica*. (in Portuguese). Thompson, Translation from English, 2003, 765 pp.
- Casetta, L., Pesce, C.P., 2006, "The Proper Definition of the Added Mass for the Water Entry Problem", 21st International Workshop on Water Waves and Floating Bodies 2nd-5th April 2006, Loughborough, United Kingdom.
- Casetta, L., Pesce, C.P., 2007, "Hamilton's Principle for Dissipative Systems and Wagner's Problem", 22nd International Workshop on Water Waves and Floating Bodies 15th-18th April 2007, Plitvice, Croatia.
- Cayley, A., 1857, "On a Class of Dynamical Problems", *Proceedings of the Royal Society of London*, Vol.8, pp. 506-511.

- Crellin, *et al.*, 1995, "Deployment and Retraction of a Continuous Tethered Satellite – the Equations Revisited", Proceedings of the Fourth International Conference on Tethers in Space, Hampton, VA, pp. 1415-1423.
- Crellin, *et al.*, 1997, "On Balance and Variational Formulations of the Equation of Motion of a Body Deploying along a Cable", *Journal of Applied Mechanics*, Vol.64, pp. 369-374.
- Cveticanin, L., 1984, "Vibrations of Textile Machine Rotor", *Journal of Sound and Vibration*, Vol.97, pp. 181-187.
- Cveticanin, L., 1989, "Stability of a Clamped-Free Rotor with Variable Mass for the Case of Radial Rubbling", *Journal of Sound and Vibration*, Vol.129, pp. 489-499.
- Cveticanin, L., 1992, "The Influence of the Reactive Force on a Nonlinear Oscillation with Variable Parameters", *Journal of Vibration and Acoustics*, Vol.114, pp. 578-580.
- Cveticanin, L., 1993a, "The Influence of the Reactive Force on the Motion of the Rotor on which the Band is Winding up", *Journal of Sound and Vibration*, Vol.167, pp. 382-384.
- Cveticanin, L., 1993b, "Conservation Laws in Systems with Variable Mass", *Journal of Applied Mechanics*, Vol.60, pp. 954-958.
- de Souza, C.A., Rodrigues, V.H., 2004, "Mass Redistribution in Variable Mass Systems", *European Journal of Physics*, Vol.25, pp. 41-49.
- Dugas, R., 1955, *A History of Mechanics*, Dover ed., 1988, 662 pp.
- Eke, F.O., Mao, T.C., 2002, "On the Dynamics of Variable Mass Systems", *International Journal of Mechanical Engineering Education*, Vol.30, No. 2, pp. 123-137.
- Ge, Z.M., 1982, "Extended Kane's Equation for Nonholonomic Variable Mass Systems", *Journal of Applied Mechanics*, Vol.49, pp. 429-431.
- Ge, Z.M., 1984, "The Equations of Motion of Nonlinear Nonholonomic Variable Mass Systems with Applications", *Journal of Applied Mechanics*, Vol.51, pp. 435-437.
- Goldstein, H., 1950, *Classical Mechanics*, Addison-Wesley Publishing Co., Massachusetts, 2nd printing, 1964, 399 pp.
- Goldstein, H., 1981, *Classical Mechanics*, Addison-Wesley Publishing Co., Massachusetts, 2nd ed., 672 pp.
- Grenwood, D.T., 1965, *Principles of Dynamics*, Prentice-Hall.
- Inglis, C., 1951, *Applied Mechanics for Engineers*, Dover Publications Edition, 1963, 404 pp.
- Irschik H., Holl, H.J., 2002, "The Equations of Lagrange Written for a Non-Material Volume", *Acta Mechanica*, Vol.153, pp. 231-248.
- Irschik H., Holl, H.J., 2004, "Mechanics of Variable-Mass Systems – Part 1: Balance of Mass and Linear Momentum", *Applied Mechanics Review*, Vol.57, No. 2, pp. 145-160.
- José, J.V., Saletan, E.J., 1998, *Classical Dynamics, a Contemporary Approach*. Cambridge University Press, re-printed, 2002, 670 pp.
- Lanczos, C., 1949, *The Variational Principles of Mechanics*. Dover Edition, 1970.
- Landau, L., Lifchitz, E., 1966, *Mécanique*, Mir Publishers, Moscow, 227 pp.
- Leitmann, G., 1957, "On the Equation of Rocket Motion", *Journal of the British Interplanetary Society*, Vol.16, No. 3, pp. 141-147.
- Levi-Civita, T., 1928, "Sul Moto di un Corpo di Massa Variabile", *Rendiconti delle Sedute della Reale Accademia dei Lincei*, Vol.8, pp. 329-333, Aggiunta alla Nota, pp. 621-622.
- Levi-Civita, T., 1930, "Ancora sul Moto di un Corpo de Massa Variable", *Rendiconti delle Sedute della Reale Accademia dei Lincei*, Vol.11, pp. 626-632.
- Levi-Civita, T., Amaldi, U., 1938, *Compendio di Meccanica Razionale*, parte seconda, Zanichelli Bologna, 310 pp.
- Meriam, J.L., 1960, "Variable-Mass Dynamics", *Journal of Engineering Education*, Vol.51, No. 3, pp. 240-243.
- Meriam, J.L., Kraige, L.G., 1987, *Dynamics*. 2nd Ed., John Wiley and Sons, Vol. 2, 641 pp.
- Meirovitch, L., 1988, *Methods of Analytical Dynamics*. McGraw-Hill, Inc., 524 pp.
- Meshchersky, I.V., 1897, *Dinamika tochki Peremnoj Massy*, St Petesburg, Akademia Nauk, Peterburskij Universitet.
- Meshchersky, I.V., 1904, "Equations of Motion of a Variable Mass Point in the General Case" (in Russian), St. Petersburg Polytechnic University News, Vol.1, pp. 77-118.
- McIver, D.B., 1973, "Hamilton's Principle for Systems of Changing Mass", *Journal of Engineering Mathematics*, Vol.7, No. 3, pp. 249-261.
- Mušicki, D., 1999, "General Energy Change Law for Systems with Variable Mass", *European Journal of Mechanics A/Solids*, Vol.18, pp. 719-730.
- Mušicki, D., 2000, "Generalization of a New Parametric Formulation of Mechanics for Systems with Variable Mass", *European Journal of Mechanics A/Solids*, Vol.19, pp. 1059-1076.
- Mušicki, D., 2005, "Extended Lagrangian Formalism and Main General Principles of Mechanics", *European Journal of Mechanics A/Solids*, Vol.24, pp. 227-242.
- Pars, L.A., 1965, *A Treatise on Analytical Dynamics*. Heinemann, London, 641pp.
- Pesce, C.P., 2003, "The Application of Lagrange Equations to Mechanical Systems with Mass Explicitly Dependent on Position", *Journal of Applied Mechanics*, Vol.70, pp. 751-756.
- Pesce, C.P., 2005, "A Note on the Classical free Surface Hydrodynamic Impact Problem", *Advances in Engineering Mechanics, reflections and Outlooks*, World Scientific Publishing Co., Singapore, pp. 390-407.

- Pesce, C.P., Tannuri, E.A., Casetta, L., 2006, "The Lagrange Equations for Systems with Mass Varying Explicitly with Position: Some Applications to Offshore Engineering", *Journal of the Brazilian Society of Mechanical Sciences and Engineering*, vol. XXVIII, no. 4, 496-504.
- Plastino, A.R., Muzzio, J.C., 1992, "On the Use and Abuse of Newton's Second Law for Variable Mass Problems", *Celestial Mechanics and Dynamical Astronomy*, Vol.53, pp. 227-232.
- Poisson, S.D., 1819, "Sur le Mouvement d'un Système de Corps, en supposant le Masses Variables", *Bull. Sci. Soc. Philomat.* Paris, avril, pp. 60-62.
- Synge, J.L., Griffith, B.A., 1959, *Principles of Mechanics*, McGraw-Hill Book Co, 3rd Ed., 552 pp.
- Sommerfeld, A., 1952, *Mechanics. Lectures on Theoretical Physics, vol. I.* Academic Press, Inc., Publishers, N.Y., 289 pp.
- Starjinski, V.M., 1986, *Mecânica Teórica*, Ed. Mir, Moscou, in Portuguese, translated from the Russian Ed., 1980, 543 pp.
- Šíma, V., Podolský, J., 2005, "Buquoy's Problem", *European Journal of Physics*, vol. 26, pp. 1037-1045.
- Tait, P.G., Steele, W.L., 1856, *A Treatise on Dynamics of a Particle*, London, McMillan.
- Targ, S., 1976, *Theoretical Mechanics, a Short Course*, Mir Publishers, Moscow, English translation, from the 2nd Russian Ed., 1974, 525 pp.
- Thorpe, J.F., 1962, "On the Momentum Theorem for a Continuous System of Variable Mass", *American Journal of Physics*, Vol.30, No. 9, pp. 637-640.
- Thompson, P.A., 1988, "Compressible-Fluid Dynamics", 665 p.
- Tiersten, M.S., 1969, "Force, Momentum Change and Motion", *American Journal of Physics*, Vol.37, No. 1, pp. 82-87.
- von Buquoy, G., 1812, "Analytische Bestimmung des Gesetzes der Virtuellen Geschwindigkeiten in Mechanischer und Statischer Hinsicht", Leipzig: Breitkopf und Hartel.
- von Buquoy, G., 1815, "Exposition d'un Nouveau Principe Général de Dynamique, d'ont le Principe des Vitesses Virtuelles n'est qu'un Cas Particulier", Paris, V Courier.
- Whittaker, E.T., 1965, *A Treatise on the Analytical Dynamics of Particles and Rigid Bodies*, Cambridge University Press, 4th ed., 456 pp.

7. RESPONSIBILITY NOTICE

The authors are the only ones responsible for the printed material included in this paper.

APPENDIX

Galilean invariance

Consider two inertial frames of reference. One of them, for simplicity and no loss of generality, is supposed fixed and the other one moves with a constant velocity, \mathbf{v}_{ref} . Let \mathbf{v} and \mathbf{v}' be the velocity of a point with respect to those frames of reference. Then, it follows that $\mathbf{v} = \mathbf{v}' + \mathbf{v}_{ref}$ and $\dot{\mathbf{v}} = \dot{\mathbf{v}}'$. Let us now show that the Newton's law in the form of Eq. (2) or (3) is invariant with respect the adopted inertial frame of reference. From Eq. (2) we have that

$$\mathbf{F} = \frac{d}{dt}(m\mathbf{v}) - \frac{dm}{dt}\mathbf{u} = \frac{dm}{dt}\mathbf{v} + m\frac{d\mathbf{v}}{dt} - \frac{dm}{dt}\mathbf{u} \quad (\text{A1})$$

Eq. (A1) can be written as

$$\mathbf{F} = \frac{dm}{dt}(\mathbf{v}' + \mathbf{v}_{ref}) + m\frac{d\mathbf{v}'}{dt} - \frac{dm}{dt}(\mathbf{u}' + \mathbf{v}_{ref}) \quad (\text{A2})$$

so that,

$$\mathbf{F} = \frac{d}{dt}(m\mathbf{v}') - \frac{dm}{dt}\mathbf{u}' \quad (\text{A3})$$

Hence, from Eqs. (A1) and (A3) it follows that the Newton's law, in one of this forms, is invariant with respect to the choice of the inertial frame of reference. Note that, on the other hand, Eq. (1) does not share this property, i.e.

$$\mathbf{F} = \frac{d}{dt}(m\mathbf{v}) = m\frac{d\mathbf{v}}{dt} + \frac{dm}{dt}\mathbf{v} = m\frac{d\mathbf{v}'}{dt} + \frac{dm}{dt}(\mathbf{v}' + \mathbf{v}_{ref}) = \frac{d}{dt}(m\mathbf{v}') + \frac{dm}{dt}\mathbf{v}_{ref} \quad (\text{A4})$$

what clearly shows the dependence of Eq. (1) on the choice of the velocity of the inertial frame of reference, unless $dm/dt \equiv 0$.

Meshchersky's Equation

See, e.g., Starjinski (1986), page 498, or Targ (1976), page 394. Consider a material volume which moves with respect to a fixed frame of reference. The mass in the interior of the material volume can vary (a discussion on the variation of mass of a material volume can be found in Irschik and Holl, 2004) with some law, $m = m(t)$. At an arbitrary instant of time t_0 , the mass of the material volume is given by $m(t_0) = M = \text{const}$. Let us now suppose that an observer follows the motion of this volume, and at a certain instant of time t_0 an amount of mass is abandoned from the material volume. Since the material volume can move in any direction, the theorem of momentum change can be applied, i.e.

$$d\left(M \frac{d\mathbf{r}_{cm}}{dt}\right) = \mathbf{F}dt, \quad (\text{A5})$$

where \mathbf{r}_{cm} is the position of the center of mass of the material volume. By integrating Eq. (A5) between the instants t_0 and $t_0 + dt$ one obtains

$$\left(M \frac{d\mathbf{r}_{cm}}{dt}\right)_{t_0+dt} - \left(M \frac{d\mathbf{r}_{cm}}{dt}\right)_{t_0} = \mathbf{F}dt. \quad (\text{A6})$$

Let us now call by $\mathbf{v} = (\dot{\mathbf{r}}_{cm})_{t_0}$ the absolute velocity of the center of mass of the material volume at the instant t_0 . Since it was supposed that after t_0 some amount of mass can be abandoned from the material volume, we thus call by $\mathbf{v} + d\mathbf{v}$ the velocity of the center of mass of the amount of mass that still remains in the considered material volume at $t_0 + dt$. Finally, \mathbf{u} is the absolute velocity of the abandoned portion of mass $-dm$, where $dm < 0$ (see Fig. 5)

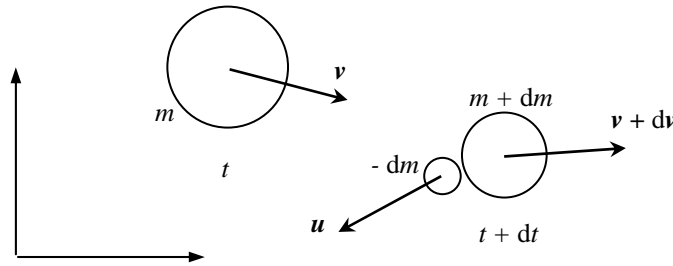

Figure 5. Motion of a variable mass material volume that abandons part of its mass

Equation (A6) can then be rewritten as,

$$[m(t_0) + dm](\mathbf{v} + d\mathbf{v}) + (-dm)\mathbf{u} - m(t_0)\mathbf{v} = \mathbf{F}dt. \quad (\text{A7})$$

Taking Eq. (A7) in the limit as $dt \rightarrow 0$ (neglecting second order terms), Meshchersky's Equation of motion for a point of variable mass is readily obtained

$$m \frac{d\mathbf{v}}{dt} = \mathbf{F} + \frac{dm}{dt}(\mathbf{u} - \mathbf{v}), \quad (\text{A8})$$

where the second term of the right-hand side is the reactive force of Meshchersky's Equation (A8) obviously recover Eq. (1) when $\mathbf{u} = 0$.

In mechanics, a variable-mass system is a collection of matter whose mass varies with time. It can be confusing to try to apply Newton's second law of motion directly to such a system. Instead, the time dependence of the mass m can be calculated by rearranging Newton's second law and adding a term to account for the momentum carried by mass entering or leaving the system. The general equation of variable-mass motion is written as. The dynamics of machines with a variable mass are treated in detail and conservation laws and the stability of motion will be analyzed. Novel finite element formulations for open systems in coupled fluid and structural dynamics are presented. Discover the world's research. Nowadays, the mechanics of variable-mass systems is recognized as a particular branch of research in theoretical and applied mechanics, being also focus of investigations in the domain of applied mathematics and physics (see, e.g., [5,6]). The unfamiliar reader can find an interesting overview in the context of mechanics in the recently published book [7]. This course is an introduction to the dynamics and vibrations of lumped-parameter models of mechanical systems. Topics covered include kinematics, force-momentum formulation for systems of particles and rigid bodies in planar motion, work-energy concepts, virtual displacements and virtual work. Students will also become familiar with the following topics: Lagrange's equations for systems of particles and rigid bodies in planar motion, and linearization of equations of motion. X. Exclude words from your search Put - in front of a word you want to leave out. For example, jaguar speed -car. Search for an exact match Put a word or phrase inside quotes. For example, "tallest building". Search for wildcards or unknown words Put a * in your word or phrase where you want to leave a placeholder.